

Big trailers series 2024

vineyard

Since 1960

ZACCARIA

QUALITY TRAILERS



vineyard

ZAM 240 BL
DOUBLE



NEW
Hydraulic suspensions
on ZAM 270 model

NEW
Alloy wheels
on demand

GRAPE TRAILER ZAM 240 BL DOUBLE BODY

Standard equipment:

60 Km per hour approval.

Watertight AISI 304 floureshed stainless steel double body.

Hydraulic two-way tipping system. Independent body.

Watertight double extension on right side with hydraulic opening.

Parabolic leaf spring suspensions with rod.

ZAM 270 Independent hydraulic suspensions with hydraulic lifting of the front axle.

Brake regulator.

Industrial axles (10 studs).

Self-steering rear and front axles.

Stainless steel light bar.

PVC water tank. PVC mudguards.

Hydraulic parking stand. PVC toolbox.

Lateral lights. Chrome wheel nut coverings. Safety support.

Optionals:

Watertight hydraulic opening of the left side extension.

Electro-hydraulic unit with remote radio control.

Steering adjuster. PVC Manual covering.

Pneumatic PVC side covering for one or two sides.

Camera and monitor kit for reverse.

NEW: Steering drawbar with hydraulic command.

NEW: ABS: Anti-lock braking system.

NEW: Alloy wheels.

LED Lights. Work lights.

K80 towing hitch.

40 mm towing hitch; F3 towing hitch.

MODEL	BODY DIMENSIONS cm	OVER SIDE H cm	HYDRAULIC SIDE H cm	VOLUME m ³	N° OF AXLES	TARE TONS	GROSS W. TONS	TIRES	BRAKE	BRAKE SIZE
ZAM 240 P03B DOUBLE BL32	320x240x130 N° 2 BODIES	70	70	25	3	6	24 + vertical load	385/55 R22,5 new	Pneumatic	406x120 10 studs
ZAM 270 P03B DOUBLE BL32	320x240x130 N° 2 BODIES			25		6,6	27 + vertical load			
ZAM 270 P03B DOUBLE BL35	350x240x130 N° 2 BODIES			27		6,9				

STANDARD COLOURS:
CHASSIS (MONOCOLOUR)

- RED ZACCARIA
- GREEN ZACCARIA
- GREEN JD ● BLUE NH
- BLACK ● GRAY IC246

OPTIONALS:

- METALLIC PAINT
- ON DEMAND COLOURS

vineyard



ZAM 240 BL DOUBLE
with double PVC manual covering

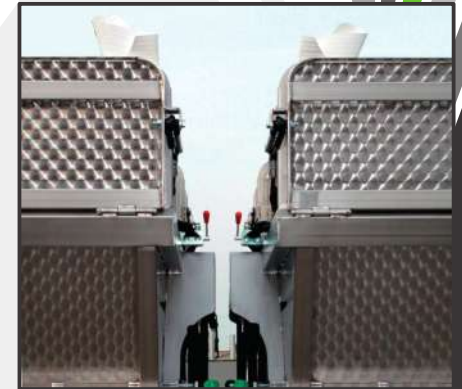

ZAM 240 BL DOUBLE
-detail-

TECHNICAL INFORMATION

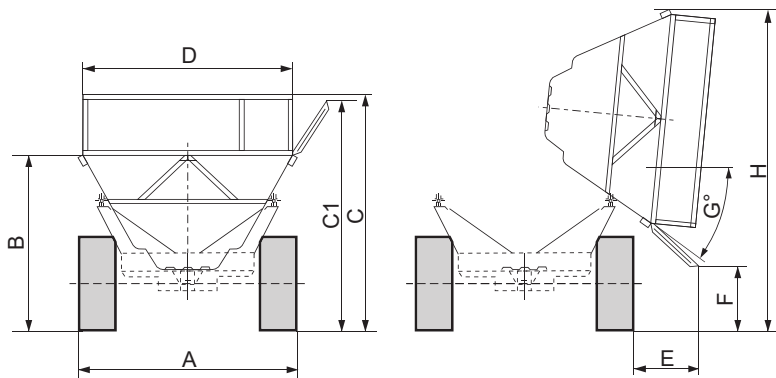

MODEL Model	A mm	B mm	C mm	C1 mm	D mm	E mm	F mm	G degrees	H mm
ZAM 240 P03B DOUBLE BL32	2450					800			
ZAM 270 P03B DOUBLE BL32	2550	2000	2700	2510	2550	750	580	31	3600
ZAM 270 P03B DOUBLE BL35	2550					750			

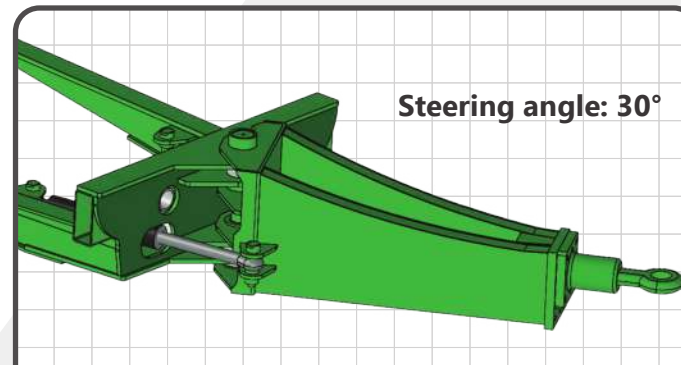

NEW: On demand, steering drawbar with hydraulic command on all the Mother Regulation trailers.



Electro-hydraulic unit with remote control

vineyard

ZAM 240 BL



OMOLOGATI MOTHER REGULATION
28
TONS max

OMOLOGATI MOTHER REGULATION
31
TONS max

GRAPE TRAILER ZAM 240 BL SUPER

Standard equipment:

- AISI 304 floureshed stainless steel body.
- Hydraulic two-way tipping system by distributor.
- Watertight extension on right side with hydraulic opening.
- Parabolic leaf spring suspensions with rod.
- ZAM 270 Independent hydraulic suspensions with hydraulic lifting of the front axle.**
- Brake regulator. Industrial axles (10 studs).
- Self-steering rear and front axles.
- Stainless steel light bar.
- PVC water tank. PVC mudguards.
- Hydraulic parking stand. PVC toolbox. Lateral lights.
- Chrome wheel nut coverings. Safety support.

Optionals:

- Watertight hydraulic opening of the left side extension.
- Electro-hydraulic unit with remote radio control.
- Removable central stainless steel cloth-holder tube.
- Steering adjuster. PVC Manual covering.
- Pneumatic PVC side covering for one or two sides.
- Camera and monitor kit for reverse.
- NEW: Steering drawbar with hydraulic command.**
- NEW: ABS: Anti-lock braking system.**
- NEW: Alloy wheels.**
- LED Lights. Work lights.
- K80 towing hitch.
- 40 mm towing hitch; F3 towing hitch.

NEW
Hydraulic suspensions
on ZAM 270 model

On demand:
60 km/h speed

NEW
Alloy wheels
on demand

MODEL	BODY DIMENSIONS cm	OVER SIDE H cm	HYDRAULIC SIDE H cm	VOLUME m ₃	N° OF AXLES	TARE TONS	GROSS W. TONS	TIRES	BRAKE	BRAKE SIZE
ZAM 240P03A BL55 SUPER	550x240x130	60	60	20	3	5	24 + vertical load	385/55 R22,5 new	Pneumatic	406x120 10 studs
ZAM 240P03A BL55 MAXI	550x240x130	70	70	21		5,3				
ZAM 240P03A BL60 MAXI	600x240x130	70	70	23		5,5				
ZAM 270 P03A BL MAXI	600x240x130	70	70	23		5,8	27 + vertical load			

STANDARD COLOURS:
CHASSIS (MONOCOLOUR)

- RED ZACCARIA
- GREEN ZACCARIA
- GREEN JD ● BLUE NH
- BLACK ● GRAY IC246

OPTIONALS:

- METALLIC PAINT
- ON DEMAND COLOURS

TECHNICAL INFORMATION

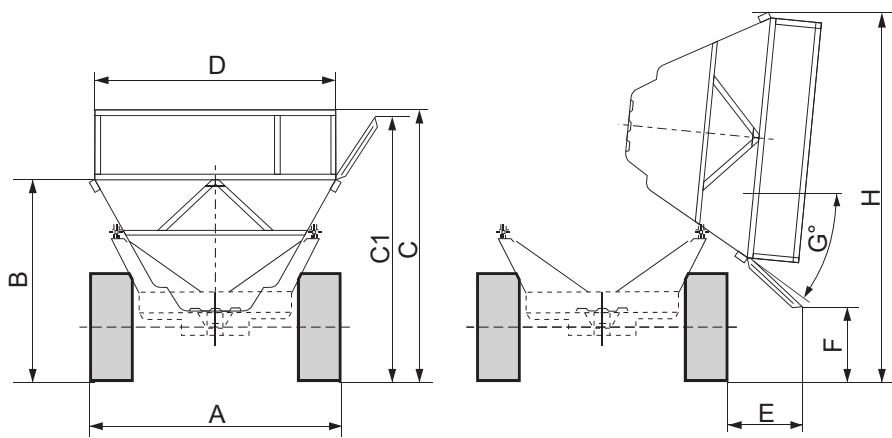

MODEL	A	B	C	C1	D	E	F	G	H
Model	mm	mm	mm	mm	mm	mm	mm	degrees	mm
ZAM 140 P02A BL45	2450	1900	2380	2280	2350	500	730	32	3400
ZAM 160 P02A BL50	2450	1900	2500	2330	2550	640	750	31	3600
ZAM 160 P02A BL50 SUPER	2450	2000	2600	2410	2550	730	660	31	3600
ZAM 240 P03A BL55 SUPER	2450	2000	2600	2410	2550	730	660	31	3600
ZAM 240 P03A BL55 MAXI	2450	2000	2700	2510	2550	800	580	31	3600
ZAM 240 P03A BL60 MAXI	2450	2000	2700	2510	2550	800	580	31	3600
ZAM 270 P03A BL60 MAXI	2550	2000	2700	2510	2550	750	580	31	3600

TIRES

New tires
385/55 R22,5
Height 1000; Width 385



vineyard



Bolted towing hitch
on all trailers



OPTIONAL:

K80 towing hitch
on all M.R. trailers

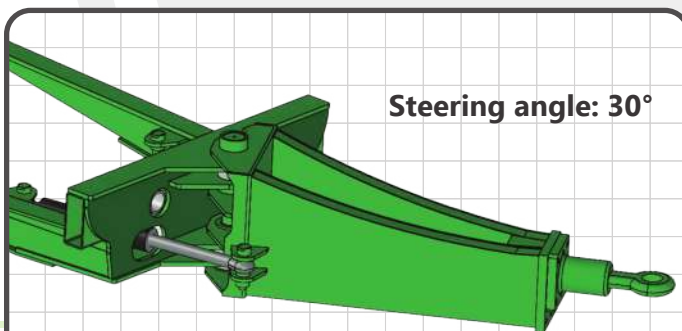

Steering angle: 30°

NEW: On demand, steering drawbar with hydraulic command on all the Mother Regulation trailers.



PVC toolbox and
PVC water tank

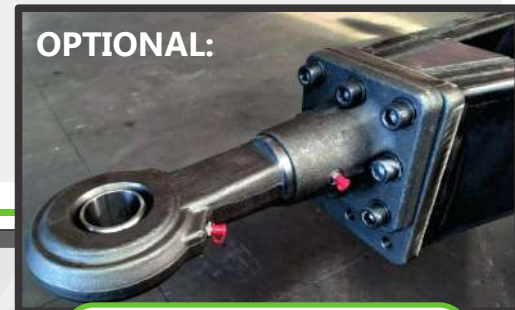

OPTIONAL:

Bolted towing hitch
with jointed kneecap

vineyard

ZAM 160 BL



GRAPE TRAILER ZAM 160 BL

Standard equipment:

- AISI 304 floureshed stainless steel watertight body.
- Hydraulic two-way tipping system by distributor.
- Watertight extension on right side with hydraulic opening.
- Parabolic leaf spring suspensions with rod.
- Brake regulator.
- Industrial axles (10 studs).
- Self-steering rear axle.
- Stainless steel light bar.
- PVC water tank. PVC mudguards.
- Hydraulic parking stand. PVC toolbox.
- Over side H 48 cm.
- Lateral lights.
- Chrome wheel nut coverings.
- Safety support.

Optionals:

- Watertight hydraulic opening of the left side extension.
- Electro-hydraulic unit with remote radio control.
- Removable central stainless steel cloth-holder tube.
- Steering adjuster. PVC Manual covering.
- Pneumatic PVC side covering for one or two sides.
- Camera and monitor kit for reverse.

NEW: Steering drawbar with hydraulic command.

NEW: ABS: Anti-lock braking system.

NEW: Alloy wheels.

- LED Lights. Work lights. K80 towing hitch.
- Bolted towing hitch with jointed kneecap.



STANDARD COLOURS CHASSIS (MONOCOLOUR)

- RED ZACCARIA
- GREEN ZACCARIA
- GREEN JD ● BLUE NH
- BLACK ● GRAY IC246

OPTIONALS:

- METALLIC PAINT
- ON DEMAND COLOURS

On demand:
60 km/h speed

NEW
Alloy wheels
on demand

MODEL	BODY DIMENSIONS cm	OVER SIDE H cm	HYDRAULIC SIDE H cm	VOLUME m ³	N° OF AXLES	TARE Tons	GROSS.W Tons	TIRES	BRAKE	BRAKE SIZE
ZAM 140 P02A BL45	450x220x120	48	48	13	2	3,4	14 + vertical load	385/55 R22,5 new	Pneumatic	406x120 10 studs
ZAM 160 P02A BL 50	500x240x130	48	48	16		4	16 + vertical load			
ZAM 160 P02A BL 50 SUPER	500x240x130	60	60	18		4,2				

GRAPE TRAILER ZAM 200 BL

Standard equipment:

AISI 304 floureshed stainless steel watertight body.
 Hydraulic two-way tipping system by distributor.
 Watertight extension on right side with hydraulic opening.
 Parabolic leaf spring suspensions
 With regulating connecting rod.
 Brake regulator (with pneumatic brake).
 Industrial axles (10 studs).
 Self-steering rear and front axles.
 Stainless steel light bar.
 PVC water tank.
 PVC mudguards.
 Hydraulic parking stand.
 PVC toolbox.

Optionals:

Watertight hydraulic opening of the left side extension.
 Electro-hydraulic unit with remote radio control.
 Steering adjuster.
 PVC Manual covering.
 Pneumatic PVC side covering for one or two sides.
 Camera and monitor kit for reverse.
 LED lights.
 Work lights.

ZAM 200 BL



vineyard

MODEL	BODY DIMENSIONS cm	OVER SIDE H cm	HYDRAULIC SIDE H cm	VOLUME m ³	N° OF AXLES	TARE Tons	GROSS W. Tons	TIRES	BRAKE	BRAKE SIZE
ZAM 200 BLP SUPER	550x240x130	60	60	20	3	4,7	20	385/55 R22,5 new	Pneumatic	406x120 10 studs
ZAM 200 BLI SUPER									Hydraulic	

STANDARD COLOURS CHASSIS (MONOCOLOUR)

- RED ZACCARIA
- GREEN ZACCARIA
- GREEN JD ● BLUE NH
- BLACK ● GRAY IC246

OPTIONALS:

- METALLIC PAINT
- ON DEMAND COLOURS

vineyard



ZAM 140 BL



ZAM 120 BL
with pneumatic PVC
side covering

STANDARD COLOURS
CHASSIS (MONOCOLOUR)

- RED ZACCARIA
- GREEN ZACCARIA
- GREEN JD ● BLUE NH
- BLACK ● GRAY IC246

OPTIONALS

- METALLIC PAINT
- ON DEMAND COLOURS

GRAPE TRAILER ZAM 120 BL / ZAM 140 BL

Standard equipment:

- AISI 304 floureshed stainless steel watertight body.
- Hydraulic two-way tipping system by distributor.
- Watertight extension on right side with hydraulic opening.
- Parabolic leaf spring suspensions with rod.
- Brake regulator (with pneumatic brake).
- Self-steering rear axle.
- Stainless steel light bar.
- PVC water tank. PVC mudguards.
- Hydraulic parking stand. PVC toolbox.
- Over side H 48 cm.

Optionals:

- Watertight hydraulic opening of the left side extension.
- Electro-hydraulic unit with remote radio control.
- Removable central stainless steel cloth-holder tube.
- Steering adjuster. PVC Manual covering.
- Pneumatic PVC side covering for one or two sides.
- LED lights. Work lights.

MODEL	BODY DIMENSIONS cm	OVER SIDE H cm	HYDRAULIC SIDE H cm	VOLUME m ³	N° OF AXLES	TARE Tons	GROSS W. Tons	TIRES	BRAKE	BRAKE SIZE
ZAM 120 BLP	450x220x120	48	48	13	2	2,9	12	385/55 R19,5 new	Pneumatic	300x90 8 studs
ZAM 120 BLI									Hydraulic	
ZAM 140 BL45P	450x220x120	48	48	13	2	3,2	14	385/55 R22,5 new	Pneumatic	400x80 10 studs
ZAM 140 BL45I									Hydraulic	
ZAM 140 BL50P	500x240x130	48	48	16,5	2	3,9	14		Pneumatic	
ZAM 140 BL50I									Hydraulic	

GRAPE TRAILER ZAM 60 BL

Standard equipment:

AISI 304 floureshed stainless steel watertight body.
Hydraulic two-way tipping by tractor distributor.
Fixed sides (**without hydraulic side**).
Galvanized light bar.
PVC mudguards. Manual parking stand.
PVC toolbox.

Optionals:

Removable central stainless steel cloth-holder tube.
PVC Water tank.
PVC Manual covering.
Hydraulic parking stand.

STANDARD COLOURS CHASSIS (MONOCOLOUR)

- RED ZACCARIA
- GREEN ZACCARIA
- GREEN JD ● BLUE NH
- BLACK ● GRAY IC246

OPTIONALS

- METALLIC PAINT
- ON DEMAND COLOURS



ZAM 60 BL

MODEL	BODY DIMENSIONS cm	OVER SIDE H cm	HYDRAULIC SIDE H cm	VOLUME m ³	N° OF AXLES	TARE Tons	GROSS W. Tons	TIRES	BRAKE	BRAKE SIZE
ZAM 60 BLI	390x210x120	20	-	8	1	15	60	355/50 R22,5 used	Hydraulic	300x90

vineyard

One axle dumper
ZAM 25/40/50 D
(from 2,5 to 5 Tons)



TECHNICAL INFORMATION

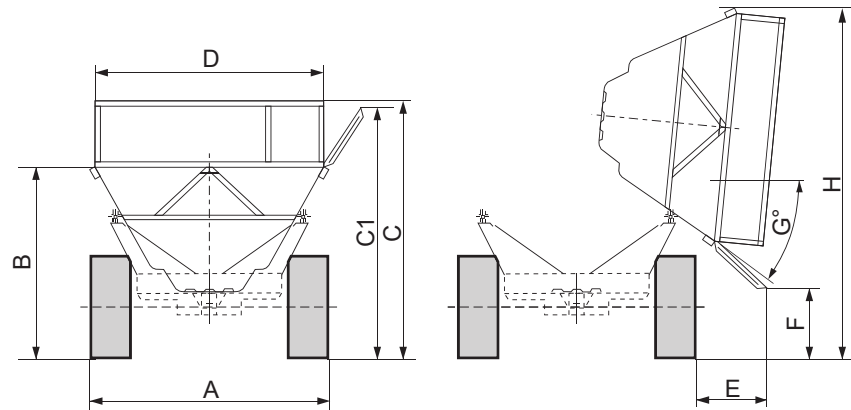

MODEL Model	A mm	B mm	C mm	C1 mm	D mm	E mm	F mm	G degrees	H mm
ZAM 60 BL	2100	1750	1950	-	2250	550	950	35	3300
ZAM 120 BL	2250	1800	2300	2200	2350	600	650	32	3350
ZAM 140 BL 45	2300	1850	2350	2250	2350	600	700	32	3400
ZAM 140 BL 50	2300	2000	2500	2400	2550	650	750	31	3600
ZAM 200 BL	2450	2000	2630	2490	2550	725	660	31	3600



Application of a
grape tank on a platform



ZAM 60DPN model in stainless steel
(from 9 to 12 m³)

PVC covering systems



**Front sliding
PVC manual covering
with crank**



**Pneumatic PVC side covering.
Right side.
Activation by remote control.**



**Pneumatic PVC side covering.
Both sides.
With cloth-holder chassis rise.
Activation by remote control.**

vineyard



zaccariarimorchi.com

ZACCARIA

QUALITY TRAILERS



ZACCARIA SRL

Via Enrico Fermi, 350

I - 41055 Montese (Modena) - Italy

Tel. +39 (0)59 981750

Fax: +39 (0)59 982353

www.zaccariarimorchi.com

info@zaccariarimorchi.com

 www.facebook.com/zaccariarimorchi

 www.linkedin.com/company/zaccaria-srl

 www.youtube.com/zaccariatrailers

 www.instagram.com/zaccaria_rimorchi

Branches and Warehouses:

I - 41015 Nonantola (Modena)

Via Zuccola, 12 - Italy



Scan the QR CODE

to see
our VIDEOS

zaccaria trailers youtube

